

Description

The HSBA6074 is the high cell density SGT N-ch MOSFETs, which provide excellent R_{DS(ON)} and gate charge for most of the synchronous buck converter applications.

The HSBA6074 meet the RoHS and Green Product requirement, 100% EAS guaranteed with full function reliability approved.

- Motor Control
- 100% EAS Guaranteed
- DC/DC Converter.
- Excellent CdV/dt effect decline
- Synchronous rectifier applications.

Product Summary

V _{DS}	60	V
R _{DS(ON),typ}	1.7	mΩ
I _D	100	A

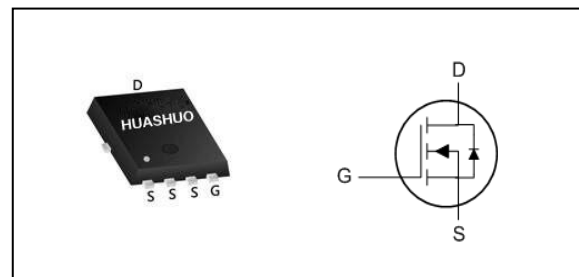
PRPAK5X6 Pin Configuration

Absolute Maximum Ratings

Symbol	Parameter	Rating	Units
V _{DS}	Drain-Source Voltage	60	V
V _{GS}	Gate-Source Voltage	±20	V
I _D @T _C =25°C	Continuous Drain Current ^{1,6}	100	A
I _D @T _C =100°C	Continuous Drain Current ^{1,6}	66	A
I _{DM}	Pulsed Drain Current ²	400	A
EAS	Single Pulse Avalanche Energy ³	306	mJ
I _{AS}	Avalanche Current	35	A
P _D @T _C =25°C	Total Power Dissipation ⁴	83	W
T _{STG}	Storage Temperature Range	-55 to 150	°C
T _J	Operating Junction Temperature Range	-55 to 150	°C

Thermal Data

Symbol	Parameter	Typ.	Max.	Unit
R _{θJA}	Thermal Resistance Junction-Ambient ¹	---	55	°C/W
R _{θJC}	Thermal Resistance Junction-Case ¹	---	1.1	°C/W

N-Ch 60V Fast Switching MOSFETs
Electrical Characteristics ($T_J=25\text{ }^\circ\text{C}$, unless otherwise noted)

Symbol	Parameter	Conditions	Min.	Typ.	Max.	Unit
BV_{DSS}	Drain-Source Breakdown Voltage	$V_{GS}=0V, I_D=250\mu A$	60	---	---	V
$R_{DS(ON)}$	Static Drain-Source On-Resistance ²	$V_{GS}=10V, I_D=20A$	---	1.7	2.1	$m\Omega$
		$V_{GS}=4.5V, I_D=20A$	---	2.3	3.2	$m\Omega$
$V_{GS(th)}$	Gate Threshold Voltage	$V_{GS}=V_{DS}, I_D=250\mu A$	1.2	---	2.3	V
I_{DSS}	Drain-Source Leakage Current	$V_{DS}=52V, V_{GS}=0V, T_J=25^\circ C$	---	---	1	μA
		$V_{DS}=52V, V_{GS}=0V, T_J=55^\circ C$	---	---	5	μA
I_{GSS}	Gate-Source Leakage Current	$V_{GS}=\pm 20V, V_{DS}=0V$	---	---	± 100	nA
g_{fs}	Forward Transconductance	$V_{DS}=5V, I_D=20A$	---	60	---	S
R_g	Gate Resistance	$V_{DS}=0V, V_{GS}=0V, f=1MHz$	---	1.6	---	Ω
Q_g	Total Gate Charge (10V)	$V_{DS}=30V, V_{GS}=10V, I_D=20A$	---	102	---	nC
Q_{gs}	Gate-Source Charge		---	16	---	
Q_{gd}	Gate-Drain Charge		---	28	---	
$T_{d(on)}$	Turn-On Delay Time	$V_{DD}=30V, V_{GS}=10V, R_G=3\Omega, I_D=20A$	---	15	---	ns
T_r	Rise Time		---	12	---	
$T_{d(off)}$	Turn-Off Delay Time		---	60	---	
T_f	Fall Time		---	19	---	
C_{iss}	Input Capacitance	$V_{DS}=30V, V_{GS}=0V, f=1MHz$	---	5480	---	pF
C_{oss}	Output Capacitance		---	1822	---	
C_{rss}	Reverse Transfer Capacitance		---	88	---	

Diode Characteristics

Symbol	Parameter	Conditions	Min.	Typ.	Max.	Unit
I_S	Continuous Source Current ^{1,5}	$V_G=V_D=0V$, Force Current	---	---	100	A
V_{SD}	Diode Forward Voltage ²	$V_{GS}=0V, I_S=1A, T_J=25^\circ C$	---	---	1.2	V
t_{rr}	Reverse Recovery Time	$I_F=20A, di/dt=100A/\mu s, T_J=25^\circ C$	---	50	---	nS
Q_{rr}	Reverse Recovery Charge		---	72	---	nC

Note :

- 1.The data tested by surface mounted on a 1 inch² FR-4 board with 2OZ copper.
- 2.The data tested by pulsed , pulse width $\leq 300\mu s$, duty cycle $\leq 2\%$
- 3.The EAS data shows Max. rating . The test condition is $V_{DD}=50V, V_{GS}=10V, L=0.5mH, I_{AS}=35A$
- 4.The power dissipation is limited by 150 $^\circ C$ junction temperature
- 5.The data is theoretically the same as I_D and I_{DM} , in real applications , should be limited by total power dissipation.
- 6.The maximum current rating is package limited.

Typical Characteristics

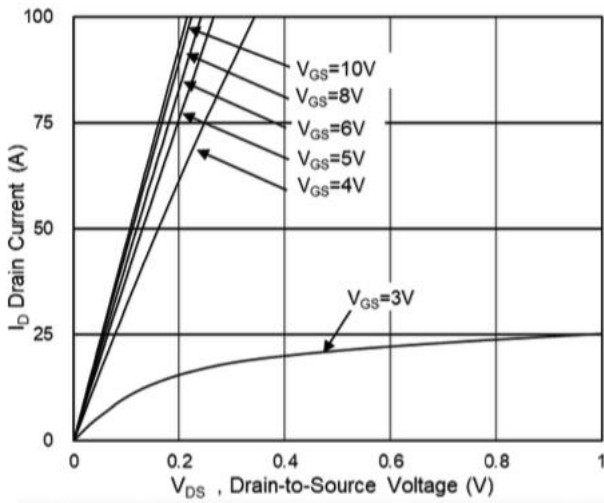

Fig.1 Typical Output Characteristics

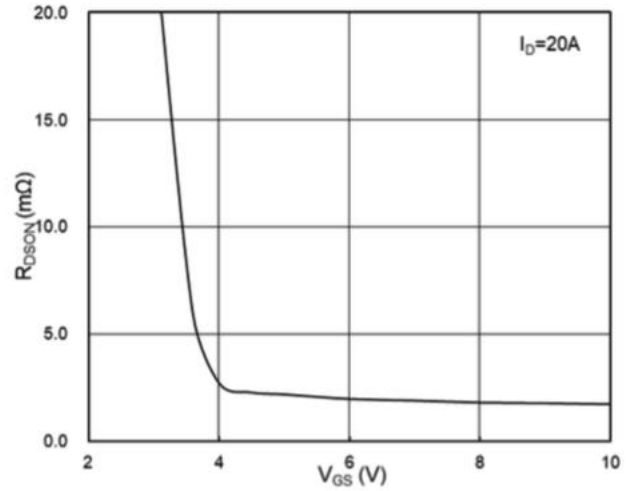

Fig.2 On-Resistance vs G-S Voltage

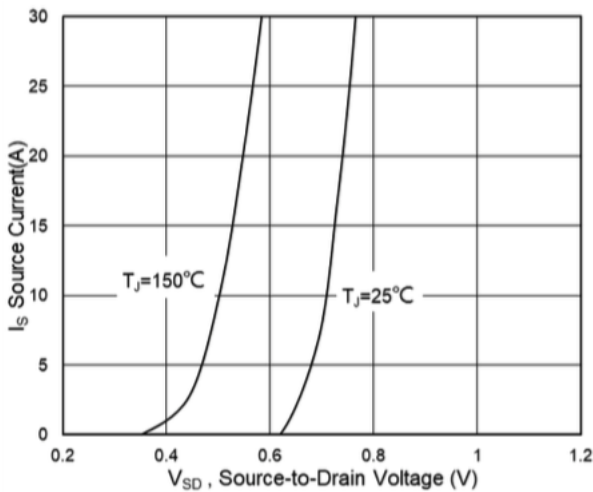

Fig.3 Diode Forward Voltage vs. Current

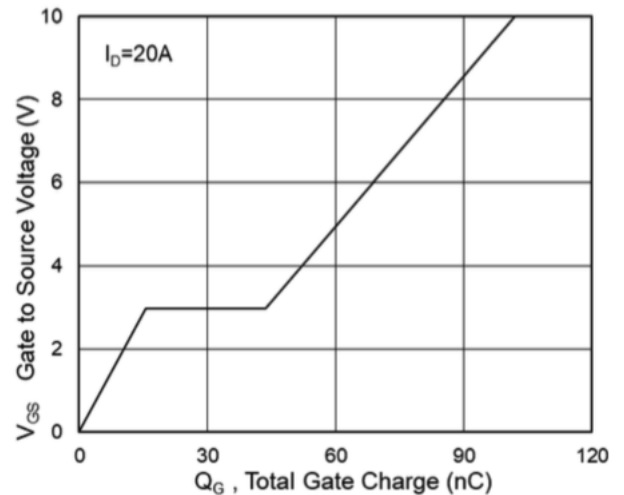

Fig.4 Gate-Charge Characteristics

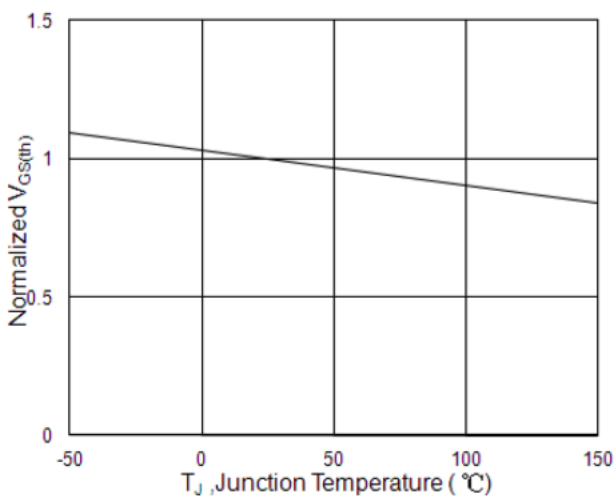

Fig.5 Normalized $V_{GS(th)}$ vs T_J

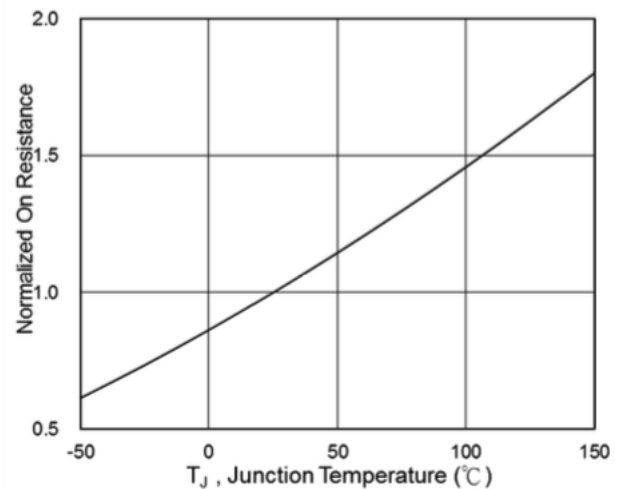

Fig.6 Normalized $R_{DS(on)}$ vs T_J

N-Ch 60V Fast Switching MOSFETs

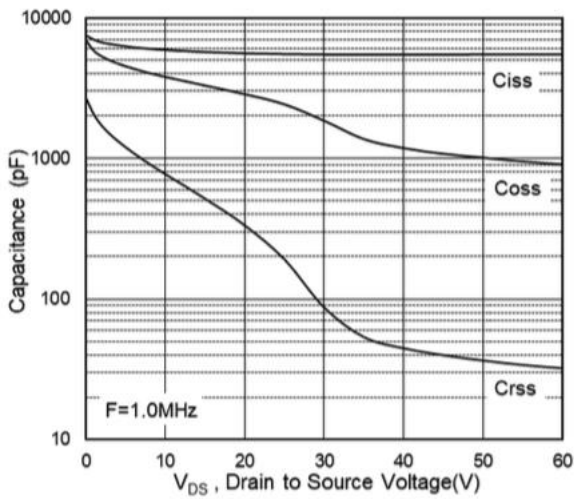

Fig.7 Capacitance

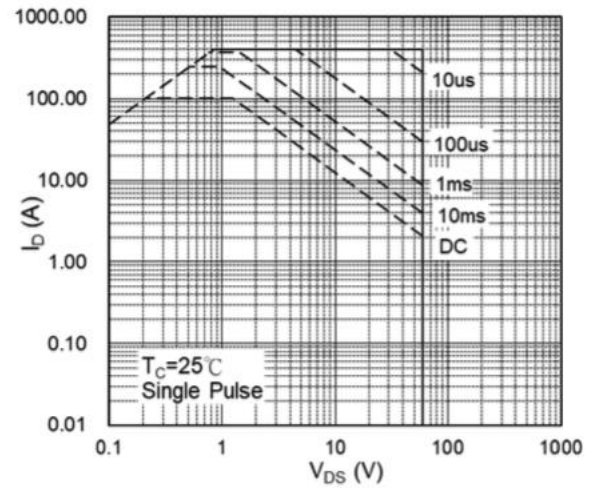

Fig.8 Safe Operating Area

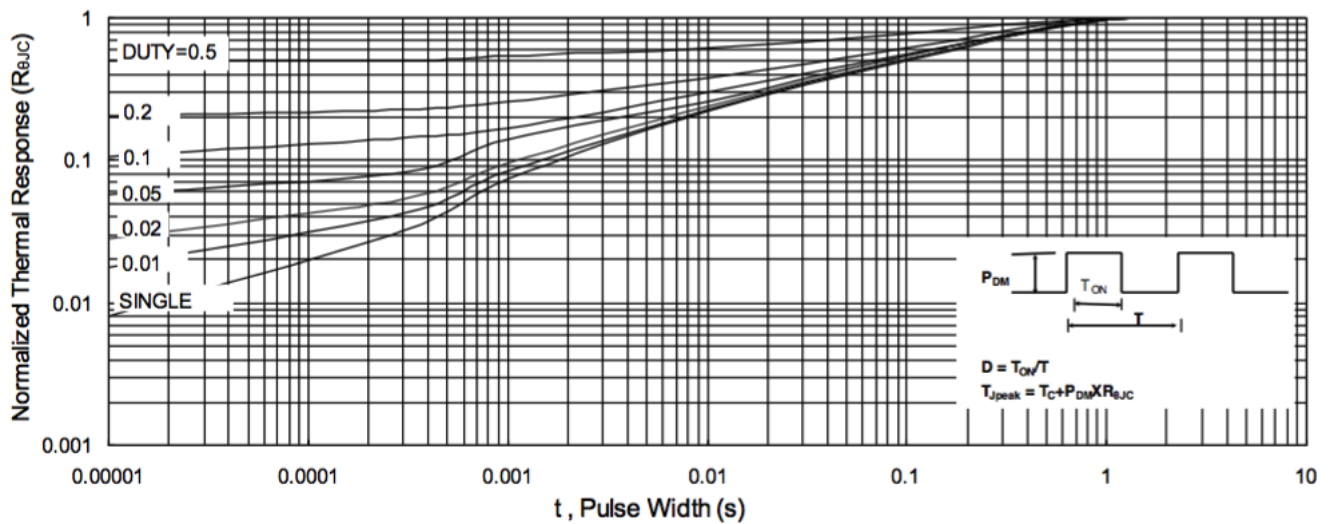

Fig.9 Normalized Maximum Transient Thermal Impedance

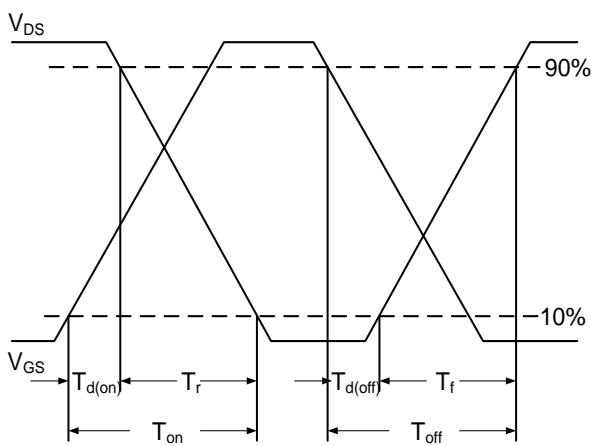

Fig.10 Switching Time Waveform

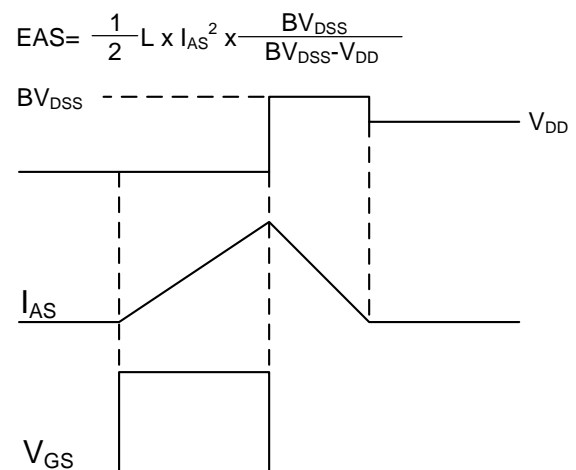
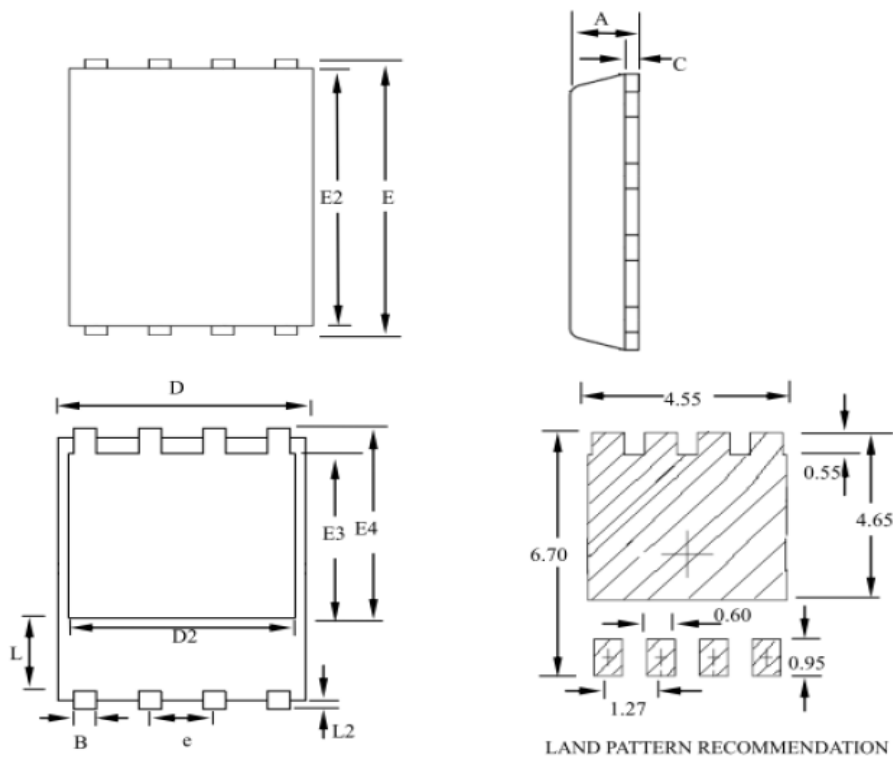

Fig.11 Unclamped Inductive Switching

Ordering Information

Part Number	Package code	Packaging
HSBA6074	PRPAK5*6	3000/Tape&Reel



SYMBOLS	MILLIMETERS			INCHES		
	MIN	NOM	MAX	MIN	NOM	MAX
A	0.80	--	1.20	0.031	--	0.047
B	0.30	--	0.51	0.012	--	0.020
C	0.15	--	0.35	0.006	--	0.014
D	4.80	--	5.30	0.189	--	0.209
D2	3.61	--	4.35	0.142	--	0.171
E	5.90	--	6.35	0.232	--	0.250
E2	5.42	--	5.90	0.213	--	0.232
E3	3.23	--	3.90	0.127	--	0.154
E4	3.69	--	4.55	0.145	--	0.179
L	0.61	--	1.80	0.024	--	0.071
L2	0.05	--	0.36	0.002	--	0.014
e	--	1.27	--	--	0.050	--